

L8542067
02/2013 rev 9

DA.24V / CP.EVA

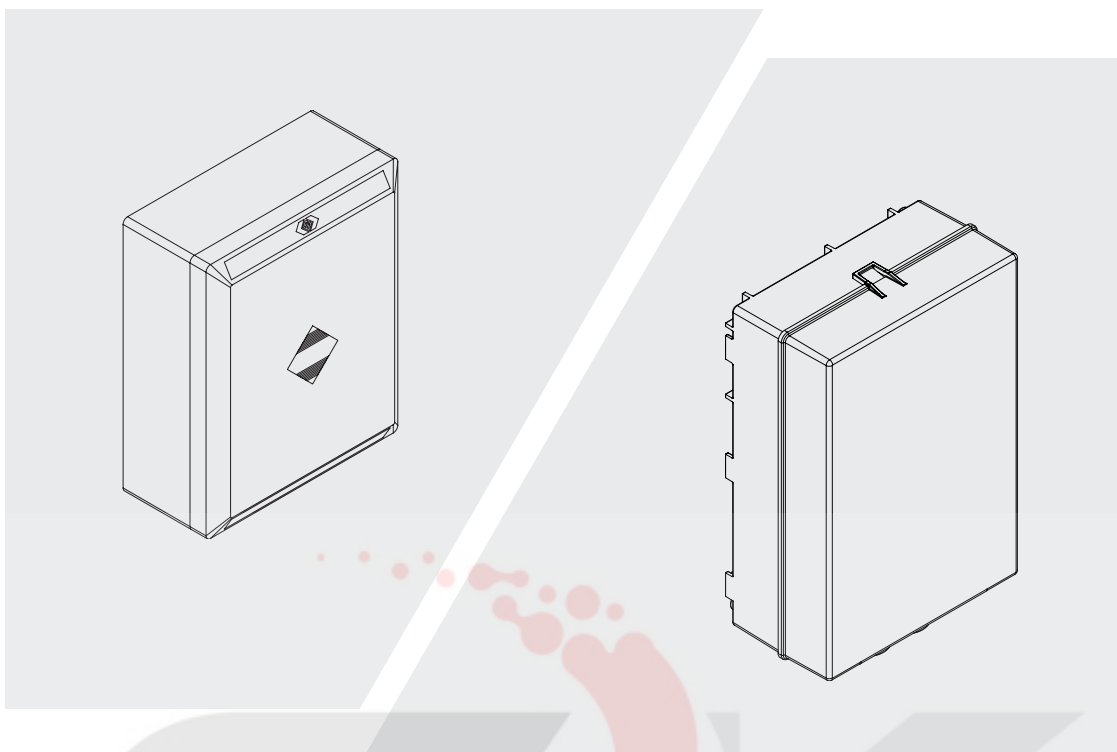

BENINCA[®]
TECHNOLOGY TO OPEN



UNIONE NAZIONALE COSTRUTTORI
AUTOMATISMI PER CANCELLI, PORTE
SERRANDE ED AFFINI



SECURITYKALA.COM

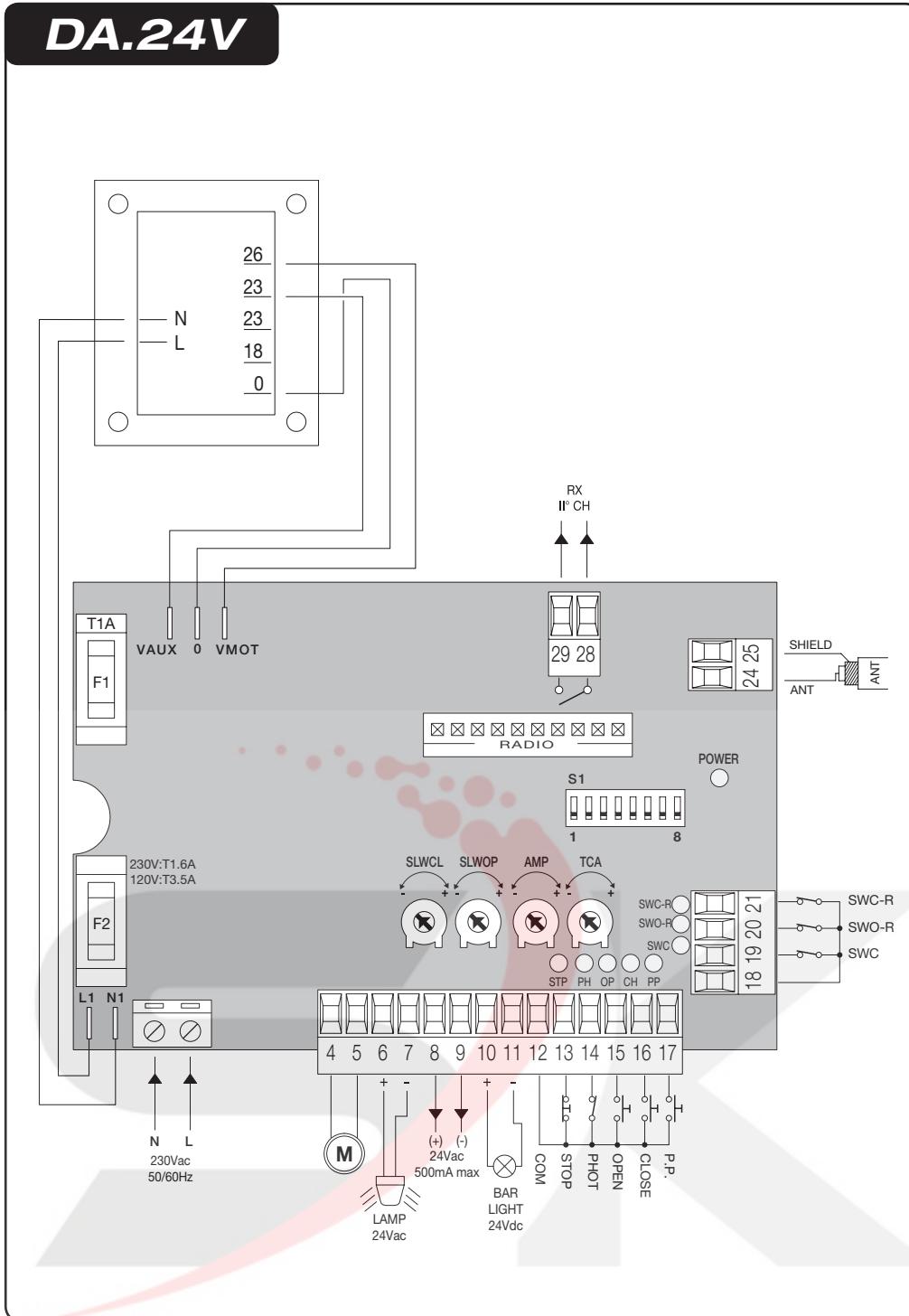

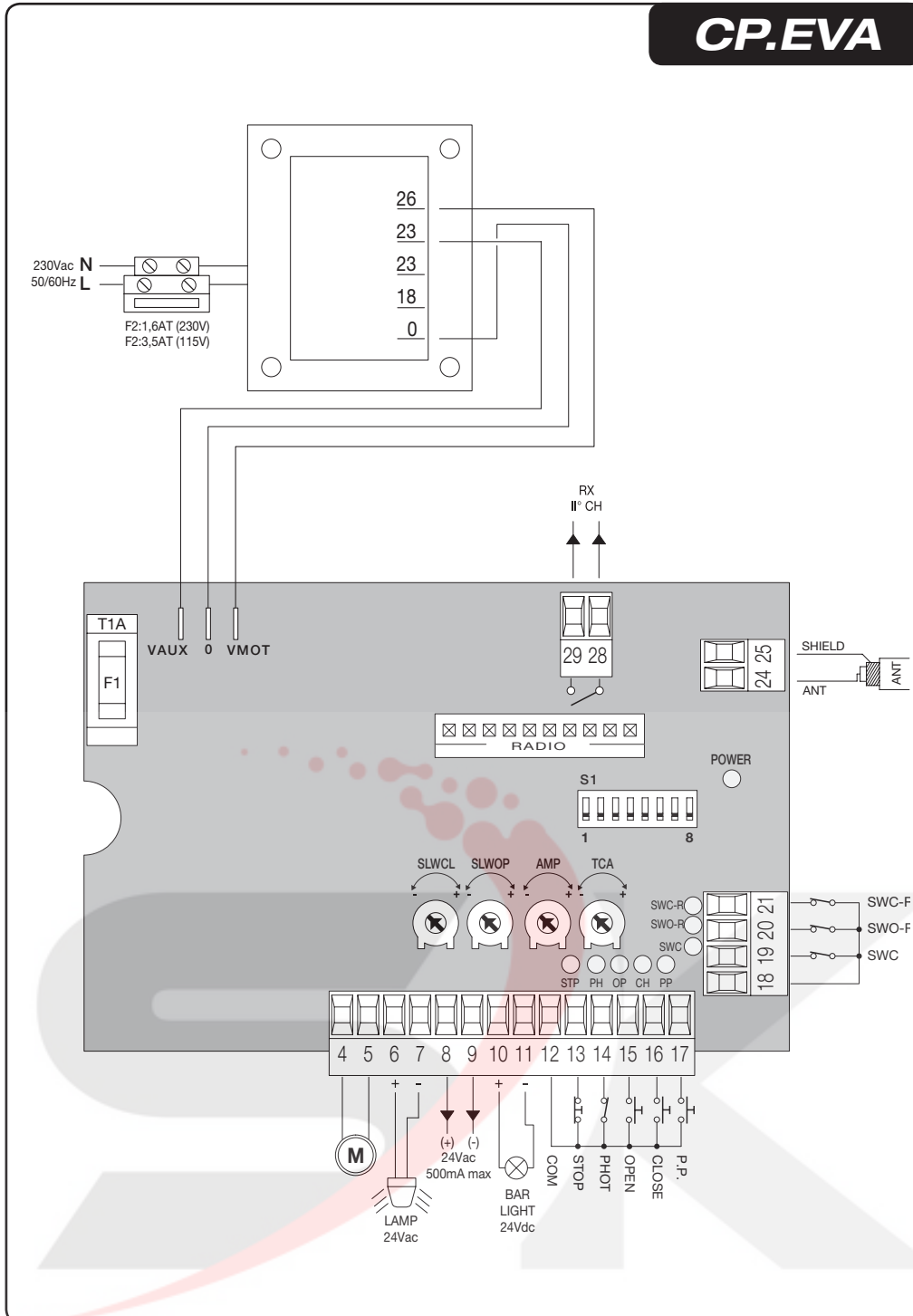

EC declaration of conformity

Declaration pursuant to Directives 2004/108/EC(EMC); 2006/95/EC(LVD)

Manufacturer: **Automatismi Benincà SpA.**

Address:

Via Capitello, 45 - 36066 Sandrigo (VI) - Italy

Declares that the product:

Command central for 1 24Vdc motor, for road barriers: DA.24V - CPEVA

is compliant with the conditions of the following EC Directives:

• **DIRECTIVE 2004/108/EC OF THE EUROPEAN PARLIAMENT AND COUNCIL** of December 15 2004 regarding the approximation of the legislations of the member States relative to electromagnetic compatibility and that repeals directive 89/336/CEE, according to the following concurred norms:

EN 61000-6-2:2005, EN 61000-6-3:2007.

• **DIRECTIVE 2006/95/EC OF THE EUROPEAN PARLIAMENT AND THE COUNCIL** of December 12 2006 concerning the approximation of the legislations of the member States relative to electrical material destined to be used within certain voltage limits, according to the following concurred regulations:

EN 60335-1:2002 + A1:2004 + A11:2004 + A12:2006 + A2:2006 + A13:2008; EN 60335-2-103:2003.

if applicable :

• **DIRECTIVE 1999/5/EC OF THE EUROPEAN PARLIAMENT AND THE COUNCIL** of March 9 1999 regarding radio devices and terminal and telecommunications devices and the reciprocal recognisances of their conformity, according to the following concurred regulations: ETSI EN 301 489-3 V1.4.1 (2002) + ETSI EN 301 489-1 V1.4.1 (2002) + ETSI EN 300 220-3 V1.1.1 (2000) + EN 60950-1 (2001)

Benincà Luigi, Legal manager.
Sandrigo, 02/11/2010.

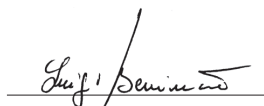

WARNINGS

This manual has been especially written to be use by qualified fitters.

None of the information provide in this manual can be considered as being of interest for the end users.

Preserve this manual for future needs.

The technician has to furnish all the information related to the step by step function, the manual and the emergency function of the operator, and to deliver the manual to the final user.



Foresee on the supply net an onnipolar switch or selector with distance of the contacts equal or superior to 3 mms.

Verify that of the electrical system there is an awry differential interrupter and overcurrent protection.

Some typologies of installation require the connection of the shutter to be link at a conductive mass of the ground according to the regulations in force.

The electrical installation and the operating logic must comply with the regulations in force.

The leads fed with different voltages must be physically separate, or they must be suitably insulated with additional insulation of at least 1 mm.

The leads must be secured with an additional fixture near the terminals.

During installation, maintenance and repair, interrupt the power supply before opening the lid to access the electrical parts

Check all the connections again before switching on the power.

The unused N.C. inputs must be bridged.

The descriptions and the present illustrations in this manual are not binding. Leaving the essential characteristics of the product unchanged, the manufacturer reserves himself the right to bring any change of technical, constructive or commercial character without undertaking himself to update the present publication.

TECHNICAL DATA

Control unit supply	24 Vdc
Power supply	230 Vac 50/60 Hz
Output supply	1 motor 24Vdc
Power maximum motor	120 W
Output supply accessories	24Vdc 500mA max.
Protection level	IP54
Operating temp.	-20°C / +50°C
Radio receiver	Removable connector for radio receiver

DA.24V/CP.EVA Control Unit**INPUT/OUTPUT FUNCTIONS**

N° of terminals	Function	Description
1-2	Power supply	Input, 230Vac 50/60Hz (1-Neutral/2-Phase)
4-5	Motor 24Vdc	Connection to motor, 24Vdc
6-7	Flasher	Flasher connection, 24Vac 40W max.
8-9	24 Vac	Output, accessories power supply - 24Vac/0.5A max. IMPORTANT: If the battery charger board CB.24V is installed, the output (without mains power connected) has a 24Vdc polarised voltage. Make sure the devices are correctly connected (i.e. 8:+24Vdc - 9:-24Vdc).
10-11	Road barrier lights	Connection of barrier beam lights, 24Vdc (10+/11+) -200mA max (equal to approx. 6 lights).
12	COM	Common to all control inputs.
13	STOP	Input, STOP push-button (N.C. contact)
14	PHOT	Input, safety devices connection, N.C. contact (ex. Photocells)
15	OPEN	Input, OPEN push-button (N.O. contact)
16	CLOSE	Input, CLOSE push-button (N.O. contact)
17	Step-by-Step	Input, step-by-step push-button (N.O. contact)
18	COM	Common, limit switches.
19	SWC	Input, CLOSURE limit switch (N.C. contact). When this contact is opened, power supply to the motor is cut-off at the end of the road barrier closing operation.

20	SWO-R	Input, braking limit switch in the opening phase (N.C. contact). When this contact is opened, braking starts during the barrier opening phase.
21	SWC-R	Input, braking limit switch in the closing phase (N.C. contact). When this contact is opened, braking starts during the barrier closing phase.
24-25	Antenna	Connection of the antenna radio receiver removable board (24-signal/25-screen).
28-29	Radio 2 nd Ch	Output, N.O. contact of the second radio channel.
VAUX-0-VMOT	Secondary	Connection of the transformer secondary winding
L1-N1	Primary	Connection of the transformer primary winding
J3	Radio receiver	Removable connector for radio receiver.

TRIMMER FUNCTIONS

- SLOWCL** The motor speed during braking in the closing phase is adjusted by this trimmer. Braking starts with the triggering of the SWC-R limit switch and ends when the SWC limit switch is activated.
- SLOWOP** The motor speed during braking in the opening phase is adjusted by this trimmer. Braking starts with the triggering of the SWO-R limit switch and ends when the time preset with Dip-Switch N°8 has elapsed.
- AMP** The obstacle detection amperometric sensor sensitivity is adjusted by this trimmer. The sensor is activated in both opening and closing phases. It is not activated during braking in the opening phase. Should an obstacle be detected:
In the opening phase, the road barrier movement is stopped.
In the closing phase, the barrier is stopped and then re-opened completely.
- TCA** This trimmer allows the adjustment of the automatic closure time if activated by Dip-Switch No. 1. The adjustment ranges between 1s minimum and 90s maximum

DIP-SWITCH FUNCTIONS

- DIP 1 "TCA"** The automatic closure is enabled or disabled
Off: disabled automatic closure
On: enabled automatic closure
- DIP 2 "PRELAM."** Forewarning flashing light is enabled or disabled
Off: disabled forewarning flashing light
On: enabled forewarning flashing light. The flashing light is activated 3s before the starting of the motor.
- DIP 3 "SCL"** (DIP 1 must be ON) This enables or disables the rapid closure function after the photocell activation.
Off: Disabled function. After the activation of the photocell, the automatic closure time remains unchanged.
On: Enabled rapid closure function. After activation of the photocell, the automatic closure time is reduced by 1 second.
- DIP 4 "P.P. Mod"** The operating mode of the "P.P. (Step-by-Step) Push button" and of the transmitter are selected.
Off: Operation: OPEN > STOP > CLOSE > STOP >
On: Operation : OPEN > CLOSE > OPEN >

- DIP 5 "LIGHT"** The operating mode of the road barrier lights connected to terminals 10/11 is selected.
Off: Slow flashing with open or closed road barrier.
Fast flashing during operation.
On: Fixed light on, with up or moving road barrier. Light off with barrier down, controlled by the triggering to the SWC-R limit switch.
- DIP 6 "COND."** The multi-flat function is enabled or disabled.
Off: disabled multi-flat function.
On: enabled multi-flat function. The P.P. (Step-by-step) impulse or the impulse of the transmitter have no effect in the opening phase and during TCA phase (if activated).
- DIP 7 "AMPCL"** The amperometric sensor is enabled or disabled during braking in the closing phase.
Off: Enabled amperometric sensor during braking in the closing phase
On: Disabled amperometric sensor during braking in the closing phase..
- DIP 8 "Trall-OP"** The amperometric sensor is activated or deactivated during braking in the opening phase.
Off: 2 sec braking with inactivated amperometric sensor.
On: 2 sec braking with activated amperometric sensor. If the amperometric sensor is activated during the 2s braking, the road barrier stops immediately its movement.

If required, the system can be controlled in SERVICE MAN mode by switching all Dip Switched to ON

TO ADJUST THE ROAD BARRIER SPEED

**WARNING! This adjustment affects the safety level of the automatic system.
Check that the force applied to the road barrier beam complies with regulations in force.
Any change in speed requires a new calibration of the amperometric sensor.**

A Faston (VMOT) connector is provided on the power supply transformer. This allows for the adjustment of the road barrier motor speed at three different levels (18-23-26).

By positioning the Faston (VMOT) to 18 a lesser speed is provided, by moving the Faston to 26 a higher speed is provided.

Should the VE.AM mobile stand or the VE.RAST rack be present, reduce the beam speed.

DIAGNOSTICS OF LEDS

The control unit is provided with a series of self-diagnostic LEDs which permit to check all functions:

POWER LED	It flashes to indicate the presence of mains power supply
STOP LED	It switches off when the STOP button is activated
PHOT LED	It switches off when the photocells are not aligned or in the presence of obstacles
OPN LED	It switches on when the OPEN button is activated
CLS LED	It switches on when the CLOSE button is activated
PP LED	It switches on when the PP button is activated
SWC LED	It switches off when the SWC closing limit switch is activated
SWO-R LED	It switches off when the SWO-R opening braking limit switch is activated
SWC-R LED	It switches off when the SWC-R closing braking limit switch is activated

WASTE DISPOSAL

If the product must be dismantled, it must be disposed according to regulations in force regarding the differentiated waste disposal and the recycling of components (metals, plastics, electric cables, etc..). For this operation it is advisable to call your installer or a specialised company.



BENINCA®

AUTOMATISMI BENINCÀ SpA - Via Capitello, 45 - 36066 Sandrigo (VI) - Tel. 0444 751030 r.a. - Fax 0444 759728

SECURITYKALA.COM